

FA810

FORK MOUNTED UJ HOOK

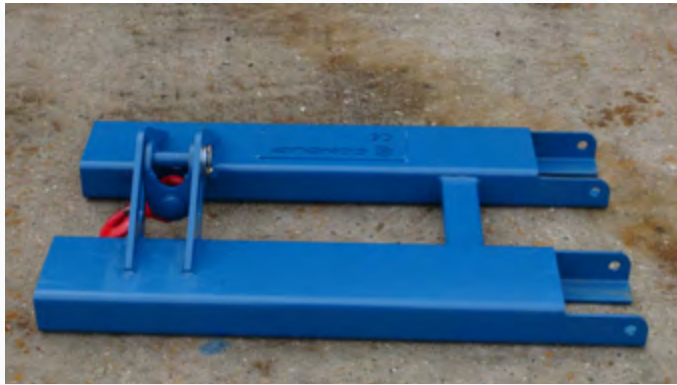
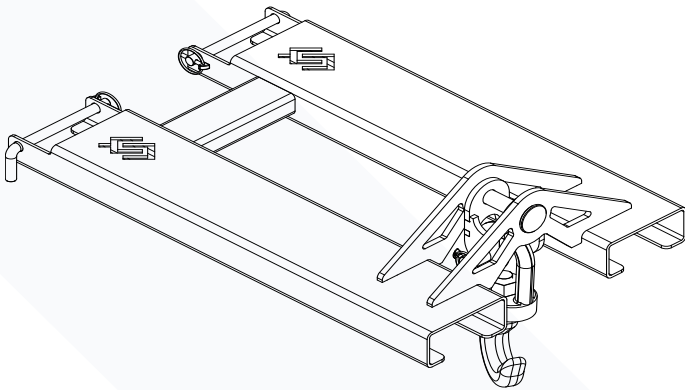

Hook folds to prevent damage in storage position

Allows movement of the hook during travel.

SWL KG	Length MM	Width MM	Fork Pockets L x H	WEIGHT KG
2000	840	520	140 X 55	35
3000	840	520	140 X 55	35

PRODUCT OVERVIEW

Improved design to the FA809, with features preventing common damage to the lifting hook. The FA810 is a quick and easy method of converting a fork lift truck into a mobile crane. The FA810 has the extra benefit of a hook that can swivel forwards and backwards allowing the tilt of the forklift to be adjusted without placing undue stress on the hook. Supplied with heel pins to secure behind the forks to prevent slipping.

Made to Measure items can be manufactured for different

CERTIFICATION

SWL and fork dimensions, please call for details.

ALL CONQUIP products are fully tested and conform to all relevant legislation, they come fully certified and CE marked on a serial plate with a unique plant number.

NOTE

THIS ITEM IS USUALLY USED WITH A DROP CHAIN OR WEBBING SLINGS BOTH OF WHICH ARE AVAILABLE FROM CONQUIP INDUSTRIAL

PHONE: 0845 520 1101
EMAIL: sales@conquip.co.uk
VISIT: www.conquip.co.uk